

QTY.	PART NUMBER
1	DREDGER-01-BASE PLINTH
1	DREDGER-02-BASE PLATE
1	DREDGER-03A-C.SHAFT PEDESTAL BASE PLATE
1	DREDGER-03B-C.SHAFT PEDESTAL TOP PLATE
2	DREDGER-03C-C.SHAFT PEDESTAL WEB PLATE
2	DREDGER-03D-GIB PLATE
2	DREDGER-03E-COTTER PLATE
2	DREDGER-04A-MAIN CRANKSHAFT BEARING BLOCK
4	DREDGER-04B-MAIN CRANKSHAFT BEARING
1	DREDGER-05A-FRONT PEDESTAL BASE PLATE
1	DREDGER-05B-FRONT PEDESTAL TOP PLATE
2	DREDGER-05C-FRONT PEDESTAL WEB PLATE
1	DREDGER-06A-BLR SHELL
1	DREDGER-06B-BLR END DOME COVER
1	DREDGER-06C-BLR CYL.TUBE
1	DREDGER-06D-BLR CYL.TUBE TOP RING
2	DREDGER-06E-BLR CYL.TUBE TOP RING STAY
1	DREDGER-06F-BLR FRONT RING
1	DREDGER-06G-BLR FRONT BOT. MOUNTING BRACKET
1	DREDGER-06H-BLR REAR BOT. MOUNTING BRACKET
1	DREDGER-06I-BLR BUSH 22x30xM16
1	DREDGER-06J-BLR BUSH 22x25xM16
1	DREDGER-06K-BLR BUSH 11x14xM6
1	DREDGER-06L-BLR BUSH 12x16xM8
1	DREDGER-06M-BLR FILLER PLUG
1	DREDGER-06N-BLR HEATER SUPPORT BRACKET
1	DREDGER-07A-BLR FRONT COVER
1	DREDGER-07B-FIRE BOX+SMOKE BOX TUBE
1	DREDGER-07C-SMOKE BOX FLANGE
1	DREDGER-07D-MANHOLE COVER
1	DREDGER-07E-FIRE DOOR SURROUND
2	DREDGER-07F-FIRE DOOR HINGE BLOCK
1	DREDGER-07G-FIRE DOOR
1	DREDGER-07H-FIRE DOOR LATCH LEVER
1	DREDGER-07I-FIRE DOOR LATCH LEVER CLASP
1	DREDGER-07J-FIRE DOOR CATCH
1	DREDGER-07K-FIRE DOOR HINGE PIN
1	DREDGER-08A-SAFETY VALVE BODY
1	DREDGER-08B-SAFETY VALVE STEM VALVE
1	DREDGER-08C-SAFETY VALVE STEM SPRING
1	DREDGER-08D-SAFETY VALVE PILLAR
1	DREDGER-08E-SAFETY VALVE PROD
1	DREDGER-08F-SAFETY VALVE WEIGHT LEVER
1	DREDGER-08G-SAFETY VALVE WEIGHT
1	DREDGER-08H-SAFETY VALVE LEVER GUARD
1	DREDGER-09A-CHIMNEY ELBOW
1	DREDGER-09B-CHIMNEY STACK
1	DREDGER-09C-CHIMNEY ELBOW TAKE OFF
1	DREDGER-10A-CYL.BARREL
1	DREDGER-10B-CYL.TOP FLANGE
1	DREDGER-10C-CYL.LOWER FLANGE
1	DREDGER-10D-CYL.BOTTOM FLANGE
1	DREDGER-10E-CYL.STEAM SUPPLY CHANNEL
1	DREDGER-10F-CYL.VALVE BLOCK
1	DREDGER-10G-CYL.VALVE BLOCK PLUG
1	DREDGER-10H-CYL.TOP COVER
1	DREDGER-10I-CYL.TOP COVER GLAND
1	DREDGER-10J-CYL.EXHAUST PIPE
1	DREDGER-10K-VALVE BUSH
1	DREDGER-10L-THROTTLE PLUG RETAINER
1	DREDGER-10M-PLUG VALVE RETAINER BRACKET
1	DREDGER-10N-PLUG VALVE RETAINER SCREW
1	DREDGER-10P-VALVE GEAR GUIDE PLATE
1	DREDGER-11A-FDWTR HEATER BODY
1	DREDGER-11B-FDWTR HEATER EXIT PIPE
1	DREDGER-11C-FDWTR HEATER WTR SUPPLY PIPE
2	DREDGER-12-CROSSHEAD GUIDE SHAFT
1	DREDGER-13A-CROSSHEAD GUIDE SHAFT BRIDGE
1	DREDGER-13B-CROSSHEAD GUIDE SHAFT STAY
1	DREDGER-13C-CROSSHEAD GUIDE SHAFT STAY
1	DREDGER-14A-DRAIN VALVE BODY
1	DREDGER-14B-DRAIN VALVE STOP
3	DREDGER-15A-WTR LVL CHECK VALVE BODY
3	DREDGER-15B-WTR LVL CHECK VALVE STOP
3	DREDGER-15C-WTR LVL VALVE STOP NUT
3	DREDGER-15D-WTR LVL VALVE PIPE NUT
1	DREDGER-15E-WTR LVL VALVE PIPE-1
1	DREDGER-15F-WTR LVL VALVE PIPE-2
1	DREDGER-15G-WTR LVL VALVE PIPE-3
1	DREDGER-16A-WTR.FD.PUMP LEVER COLUMN
1	DREDGER-16B-DUMMY WTR.FD.PUMP
1	DREDGER-16C-DUMMY WTR.FD.PUMP PIPE NUT

QTY.	PART NUMBER
1	DREDGER-16D-WTR.FD.PUMP EXIT PIPE
1	DREDGER-17A-CHECK VALVE BODY
1	DREDGER-17B-CHECK VALVE BALL VALVE
1	DREDGER-17C-CHECK VALVE SCEW TOP
1	DREDGER-17D-CHECK VALVE PIPE NUT
1	DREDGER-50A-CRANKSHAFT
1	DREDGER-50B-CRANKWEB
1	DREDGER-50C-CRANK PIN
1	DREDGER-50D-DRIVE COG WHEEL
1	DREDGER-50E-FLYWHEEL
1	DREDGER-50F-FLYWHEEL CRANK PIN
1	DREDGER-50G-CRANKSHAFT SPACER
1	DREDGER-51A-PISTON
1	DREDGER-51B-PISTON ROD
2	DREDGER-52A-CROSSHEAD PLATE
2	DREDGER-52B-CROSSHEAD OUTER SPACER
1	DREDGER-52C-CROSSHEAD CENTER SPACER
2	DREDGER-52D-CROSSHEAD INNER WEB
2	DREDGER-52F-CROSSHEAD BEARING SHAFT
4	DREDGER-52G-CROSSHEAD SLIDING BUSH
1	DREDGER-52H-CROSSHEAD VALVE GEAR PIVOT
2	DREDGER-53A-CON-ROD BODY
4	DREDGER-53B-CON-ROD BEARING STRAP
4	DREDGER-53C-CON-ROD BEARING
4	DREDGER-53D-CON-ROD COTTER
1	DREDGER-54A-THROTTLE PLUG
1	DREDGER-54B-THROTTLE PLUG HANDLE
1	DREDGER-55A-PLUG VALVE
1	DREDGER-55B-PLUG VALVE LEVER
1	DREDGER-56A-VALVE GEAR OPERATING LINK
1	DREDGER-56B-VALVE GEAR GUIDE STRIP
2	DREDGER-56C-VALVE GEAR GUIDE STRIP SPACER
1	DREDGER-56D-VALVE GEAR STRIKER-1
1	DREDGER-56E-VALVE GEAR STRIKER-2
1	DREDGER-57A-WATER FEED PUMP YOKE
1	DREDGER-57B-WATER FEED PUMP LEVER
4	DREDGER-57C-WATER FEED PUMP PIVOT BOLT
1	DREDGER-57D-WATER FEED PUMP PISTON
1	DREDGER-57E-WATER FEED PUMP PISTON ROD
1	DREDGER-M2.5 NUT
29	DREDGER-M3 NUT
1	DREDGER-M3 NUT BRASS
1	DREDGER-M3 WASHER BRASS
2	DREDGER-M3x6 C-SINK SCREW
5	DREDGER-M3x6 HEX BOLT
16	DREDGER-M3x8 HEX BOLT
4	DREDGER-M3x10 HEX BOLT
6	DREDGER-M3x12 HEX BOLT
2	DREDGER-M3x20 HEX BOLT
6	DREDGER-M4 DOME NUT
33	DREDGER-M4 NUT
24	DREDGER-M4x10 HEX BOLT
4	DREDGER-M4x12 C-SINK SCREW BRASS
6	DREDGER-M4x14 STUD
10	DREDGER-M4x16 HEX BOLT
12	DREDGER-M4x20 HEX BOLT
36	DREDGER-M5 DOME NUT
13	DREDGER-M5 NUT
39	DREDGER-M5x16 HEX BOLT
8	DREDGER-M5x16 STUD
2	DREDGER-M5x22 HEX BOLT
2	DREDGER-M5x24 STUD
8	DREDGER-M6 NUT
8	DREDGER-M6x20 HEX BOLT
2	DREDGER-M10 NUT

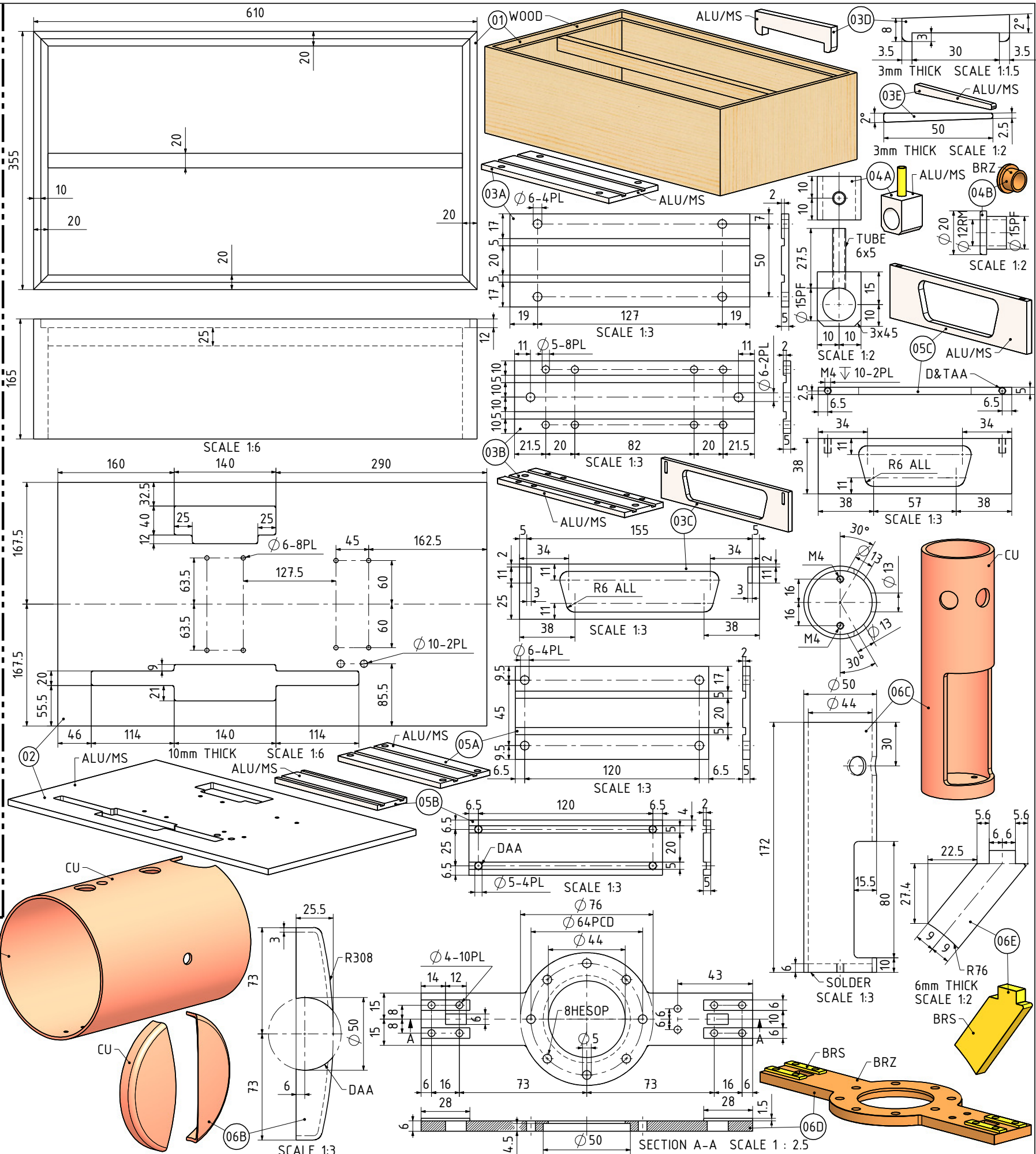

NOTES: THE ORIGINAL DRAWINGS WERE GIVEN TO ME. THE ARTICLE AND DRAWINGS WERE PUBLISHED IN THE "MODEL ENGINEER" MAGAZINE OF SEPTEMBER 1987. THE DESIGN AND BUILT WAS BY TUBAL CAIN.

TITLE
MODEL OF THE HIGH PRESSURE DREDGER ENGINE OF RICHARD TREVITHICK OF 1806

DRAWING CONTENTS
BILL OF MATERIALS, PARTS AND ASSEMBLIES

PROJECT No 09E-20-00
 JDW DRAUGHTING SERVICES
 J.A.M. DE WAAL, 12 BRIGHTWELL STREET PAPAURA 2110,
 NEW ZEALAND. PHONE: 0064 09 2988815. MOB: 0211791000
 E-MAIL: dewaal@xtra.co.nz.

PROJECTION
 DATE JULY-2016
 SHEET: 04 OF 09
 MODEL SCALE: 1:1
 DWG SCALE: 1:1 @A3 OR AS SHOWN
 Copyright © J.A.M. DE WAAL PAPAURA NZ
 A3 No: DREDGER-04