

OTHER ABBREVIATIONS
 AS = AS SHOWN
 DP = DEEP
 DAA= DRILL AFTER ASSEMBLY
 D&TAA= DRILL AND TAP AFTER ASSEMBLY
 CF = CLOSE FIT (SIZE FOR SIZE)
 PF = PRESS FIT
 PFAA= PRESS FIT AFTER ASSEMBLY
 PCD = PITCH CIRCLE DIAMETER
 RM = REAM
 HEX = HEXAGON, 6SIDED
 CP = COMPRESSED
 KNL = KNURLED
 CSK = COUNTERSINK
 PL = PLACES
 DWL= DOWEL
 SPF= SPOTFACE
 (T)HESOP=(TAPPED)HOLES EQUALLY SPACED ON PCD
 (T)HESOC=(TAPPED)HOLES EQUALLY SPACED ON CIRCUMFERENCE
 OD = OUTSIDE DIAMETER
 ID = INSIDE DIAMETER
 MAX/MIN = CRITICAL DIMENSION
 [SA-xxx]= SUB ASSEMBLY-xxx

GENERAL NOTES:
 0. ALL DRAWINGS ARE IN METRIC MEASUREMENTS
 1. ALL ENGINEERING PRACTICES SHALL BE APPLIED WITH REGARDS TO HOLE AND SHAFT TOLERANCES.
 2. WHERE SCREWS OR BOLTS ARE USED THE CLEARANCE HOLES SHALL BE APPROXIMATELY 5% TO 8% LARGER THAN THE MATCHING TAPPED HOLE.
 3. PREFERABLY ALL TAPPED HOLES AND MATCHING SCREWS AND/OR BOLTS TO BE METRIC FINE (MF)
 4. MATERIALS SPECIFIED ON THE DRAWINGS ARE INDICATIVE ONLY. THE BUILDER CAN MAKE HIS/HER OWN MATERIAL CHOICE.
 5. ALL CONNECTIONS/JOINTS WHICH HAVE STEAM PRESSURE APPLIED TO IT SHALL BE SILVER/HARD SOLDERED.
 6. COMPRESSION SPRINGS ARE DRAWN IN COMPRESSED STATE (CP), UNCOMPRESSED STATE IS APPROX 40% TO 60% LONGER THEN COMPRESSED STATE.
 7. WHERE PREFERRED SCREW OR RIVETED CONNECTIONS CAN BE OMITTED AND PARTS CAN BE BONDED TOGETHER BY USING EITHER HIGH STRENGTH GLUE, EPOXY RESIN, OR SOLDER.
 8. PARTS WHICH ARE DIRECTLY EXPOSED TO STEAM AND/OR WATER SHOULD BE CONSTRUCTED USING NON-FERROUS OR NON CORROSIVE MATERIAL SUCH AS BRASS, BRONZE, GUNMETAL, STAINLESS STEEL, COPPER OR MONEL.
 9. THE ORDER IN WHICH THE PARTS/COMPONENTS ARE MANUFACTURED AND THE MODEL IS ASSEMBLED IS ENTIRELY LEFT TO THE BUILDER/MODEL MAKER.
 10. A COLOUR SCHEME FOR THIS PROJECT IS ENTIRELY LEFT UP TO THE MODEL MAKER.
 11. THE MANNER IN WHICH THE PARTS/COMPONENTS ARE MANUFACTURED IS ENTIRELY LEFT UP TO THE BUILDER.
 12. USE LOCTITE, ON SCREW OR PRESS FIT CONNECTIONS OR SURFACES, WERE DEEMED NECESSARY TO PREVENT PARTS FROM LOOSENING.
 13. WASHERS AND/OR SPRING WASHERS SHALL BE USED WHERE DEEMED NECESSARY.
 14. REMOVE ALL SHARP EDGES.
 XX. ERRORS AND/OR OMISSIONS MAY OCCUR IN THE DRAWINGS, DO NOT HESITATE TO CONTACT ME SO THAT THE ERRORS/OMISSIONS CAN BE RECTIFIED.

ADDITIONAL NOTES ABOUT THESE DRAWINGS:
 1) NO MATERIALS HAVE BEEN SPECIFIED ON THESE DRAWINGS. THE BUILDER TO CHOOSE ITS OWN PREFERRED MATERIAL FOR THE PARTS/COMPONENTS. THE FOLLOWING COLOURS ON THE DRAWINGS INDICATES POSSIBLE MATERIALS WHICH CAN BE USED FOR PARTS: YELLOW=BRASS, LIGHT GREY=ALUMINIUM OR MILD STEEL, REDDISH BROWN=COPPER, DARK BROWN=BRONZE OR GUN METAL, WHITISH=SILVER STEEL OR STAINLESS STEEL
 2) FASTENERS. NO FASTENERS SUCH AS BOLTS, SCREWS, RIVETS, SPLITPINS, NUTS AND WASHERS HAVE BEEN SHOWN ON THESE DRAWINGS. THE BUILDER TO CHOOSE ITS OWN PREFERRED TYPE OF FASTENERS.

DUE TO THE LACK OF INFORMATION ON THE ORIGINAL DRAWING(S), SUCH AS VIEWS, DIMENSIONS, SECTIONS ETC AND/OR CLARITY OF COMPONENTS, OMITTED PARTS/COMPONENTS, SOME OF THE COMPONENTS MIGHT NOT BE AS CONSTRUCTED ORIGINALLY OR AS THE ORIGINAL DESIGNER INTENDED

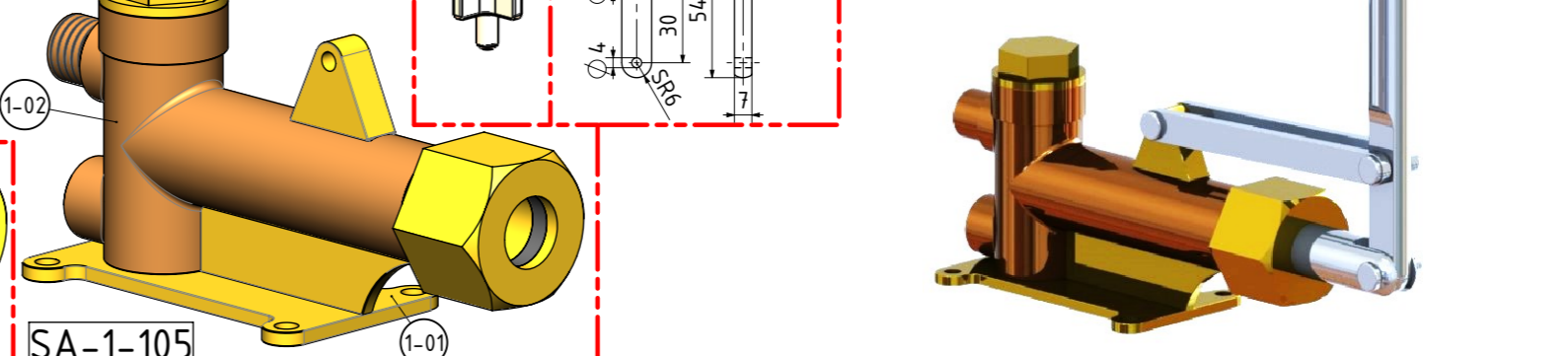
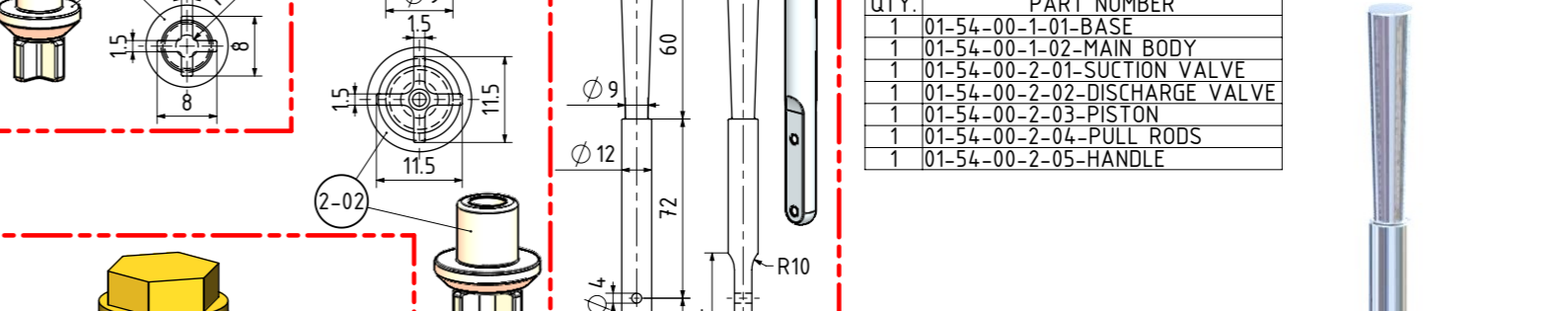
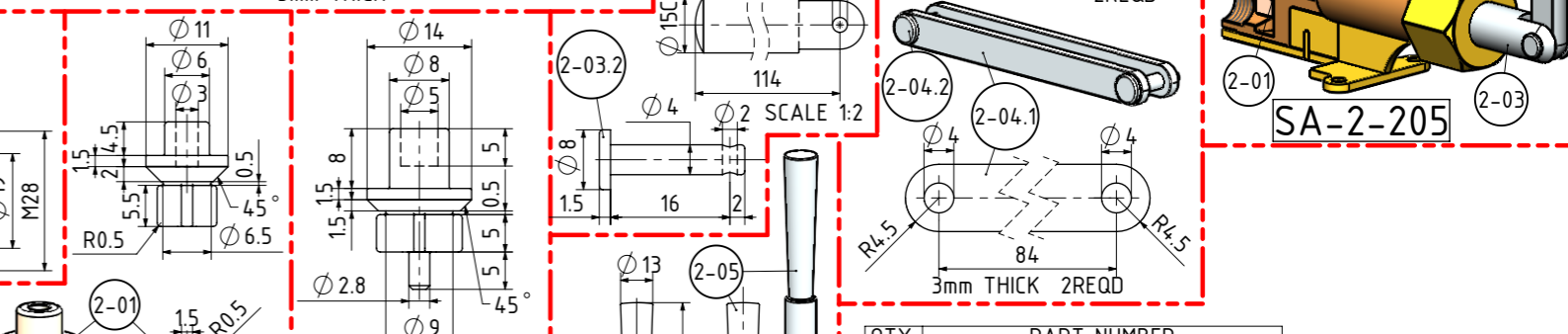
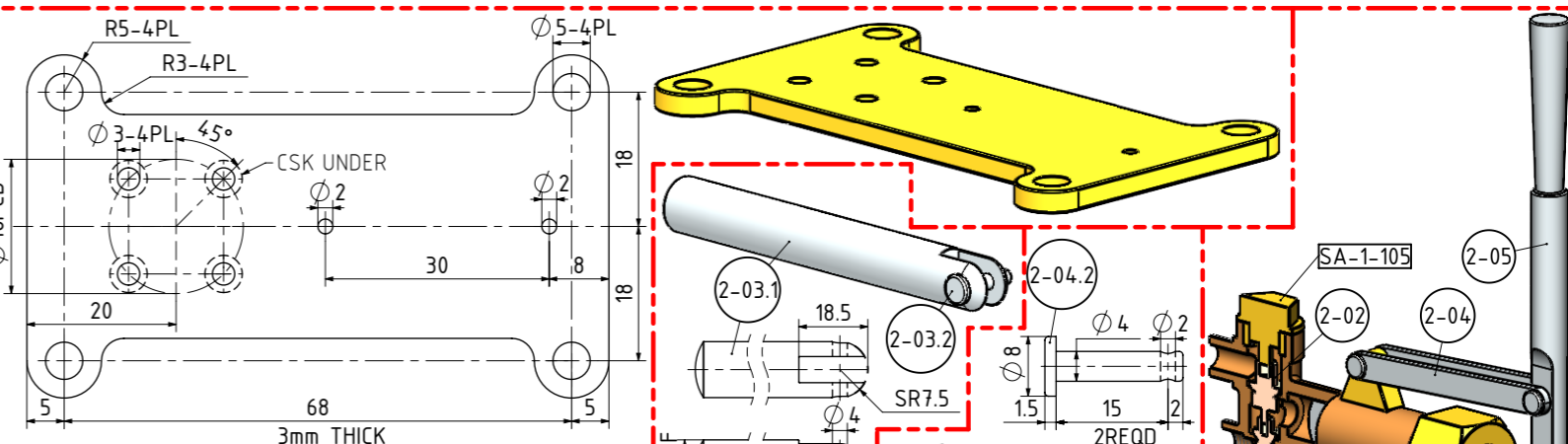
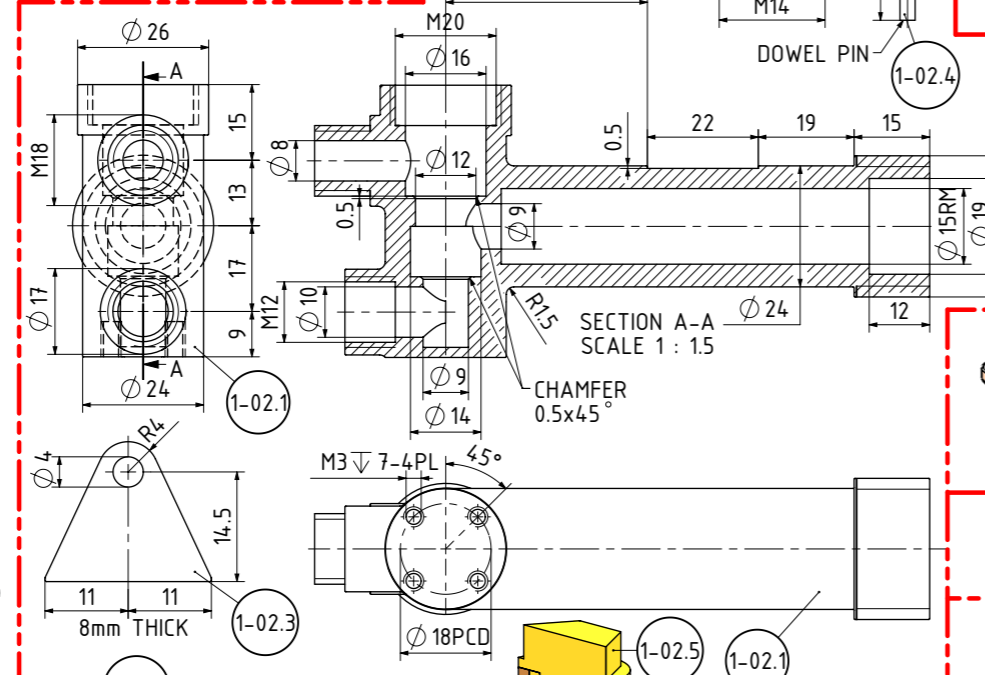
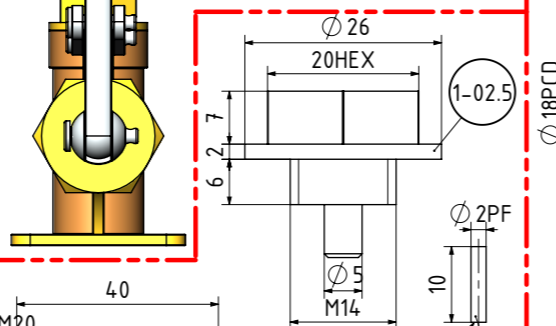
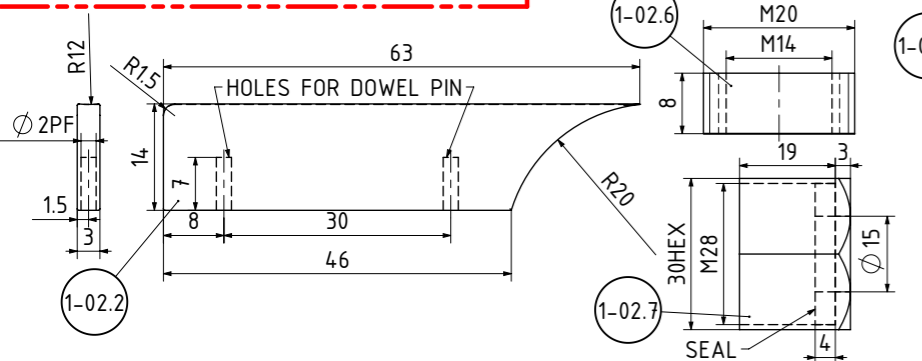
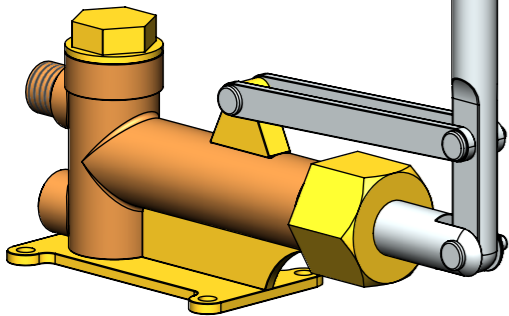

QTY.	PART NUMBER
1	01-54-00-1-01-BASE
1	01-54-00-1-02-MAIN BODY
1	01-54-00-2-01-SUCTION VALVE
1	01-54-00-2-02-DISCHARGE VALVE
1	01-54-00-2-03-PISTON
1	01-54-00-2-04-PULL RODS
1	01-54-00-2-05-HANDLE

NOTES: FOUND THE ORIGINAL DRAWINGS IN A DUTCH MAGAZINE "DE MODELBOUWER" OF 15 JULY 1948. THE DESIGN AND DRAWINGS WERE BY H.J.H.BOSMAN, ZEIST, HOLLAND

TITLE
A VERY SIMPLE BOILER HAND OPERATED FEED PUMP

DRAWING CONTENTS
G.A. NOTES, PARTS & ASSEMBLIES, BILL OF MATERIALS

PROJECT No 01-54-00
 JDW DRAUGHTING SERVICES
 J.A.M. DE WAAL, 12 BRIGHTWELL STREET PAPAOKURA
 2110, NEW ZEALAND. PHONE: 0064 09 2988815. MOB: 0211791000 E-MAIL: dewaal@xtra.co.nz.

PROJECTION
 DATE NOVEMBER 2023
 SHEET: 01 OF 01
 MODEL SCALE: 1:1
 DWG SCALE: 1:1 @A3 OR AS SHOWN
 Copyright © J.A.M. DE WAAL PAPAOKURA NZ
 A3 No:01-54-00-SHT01
 DRAWINGS ARE FOR PERSONAL USE ONLY NOT FOR COMMERCIAL PURPOSES