

THE OFF SET ANGLE OF THE ECCENTRIC IN RELATION TO THE CRANK AXIS TO BE EXPERIMENTALLY DETERMINED FOR THE SMOOTH RUNNING OF THE ENGINE AND SATISFACTION OF THE BUILDER

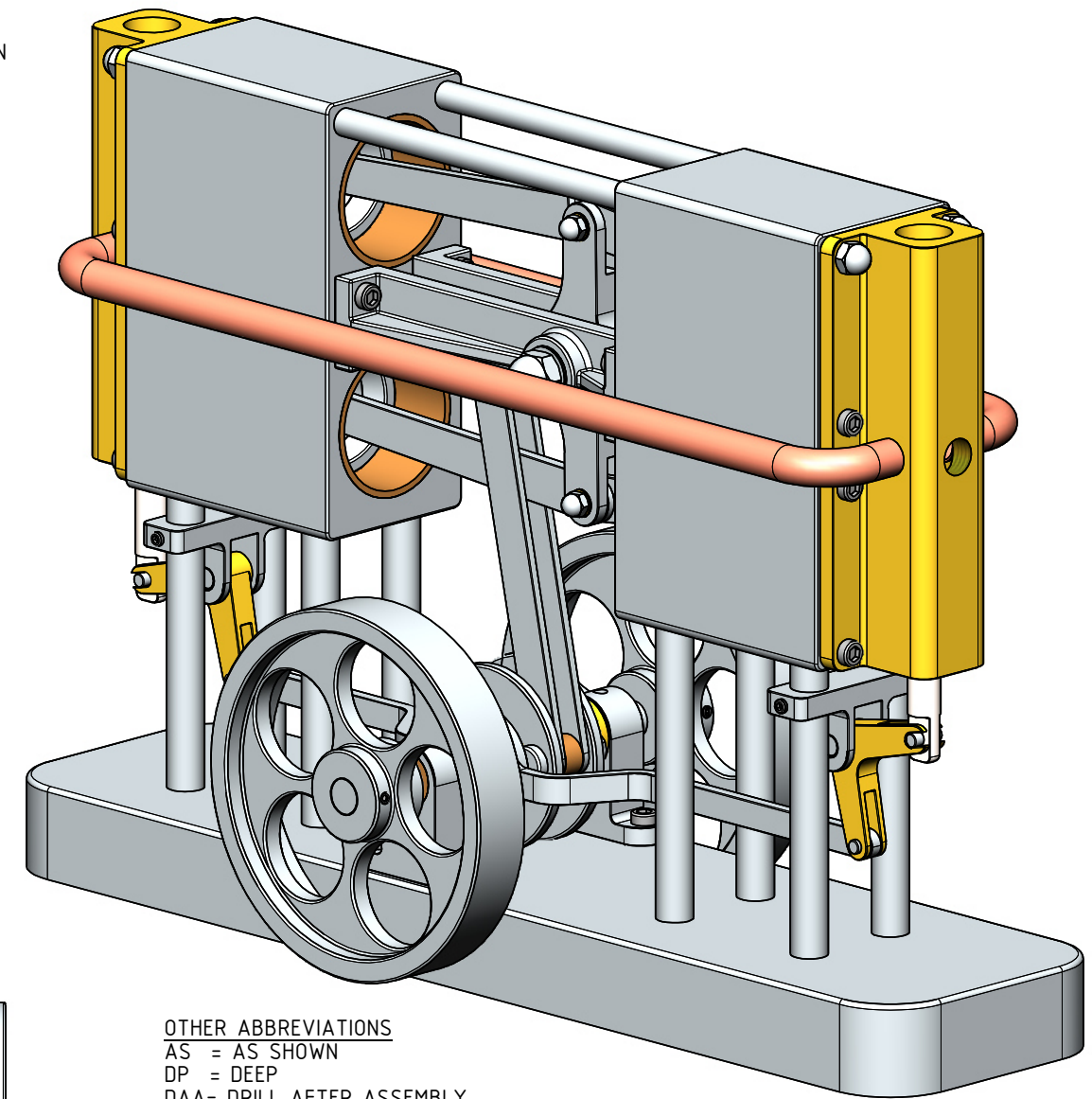
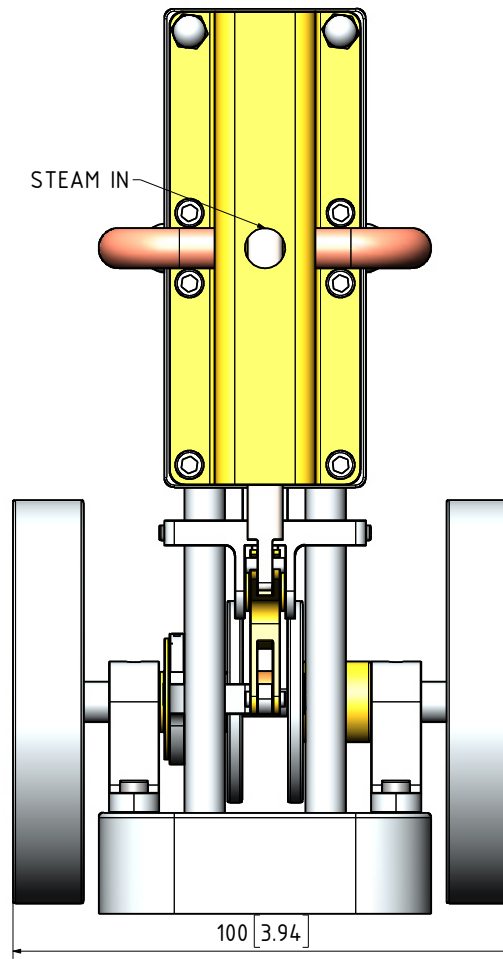
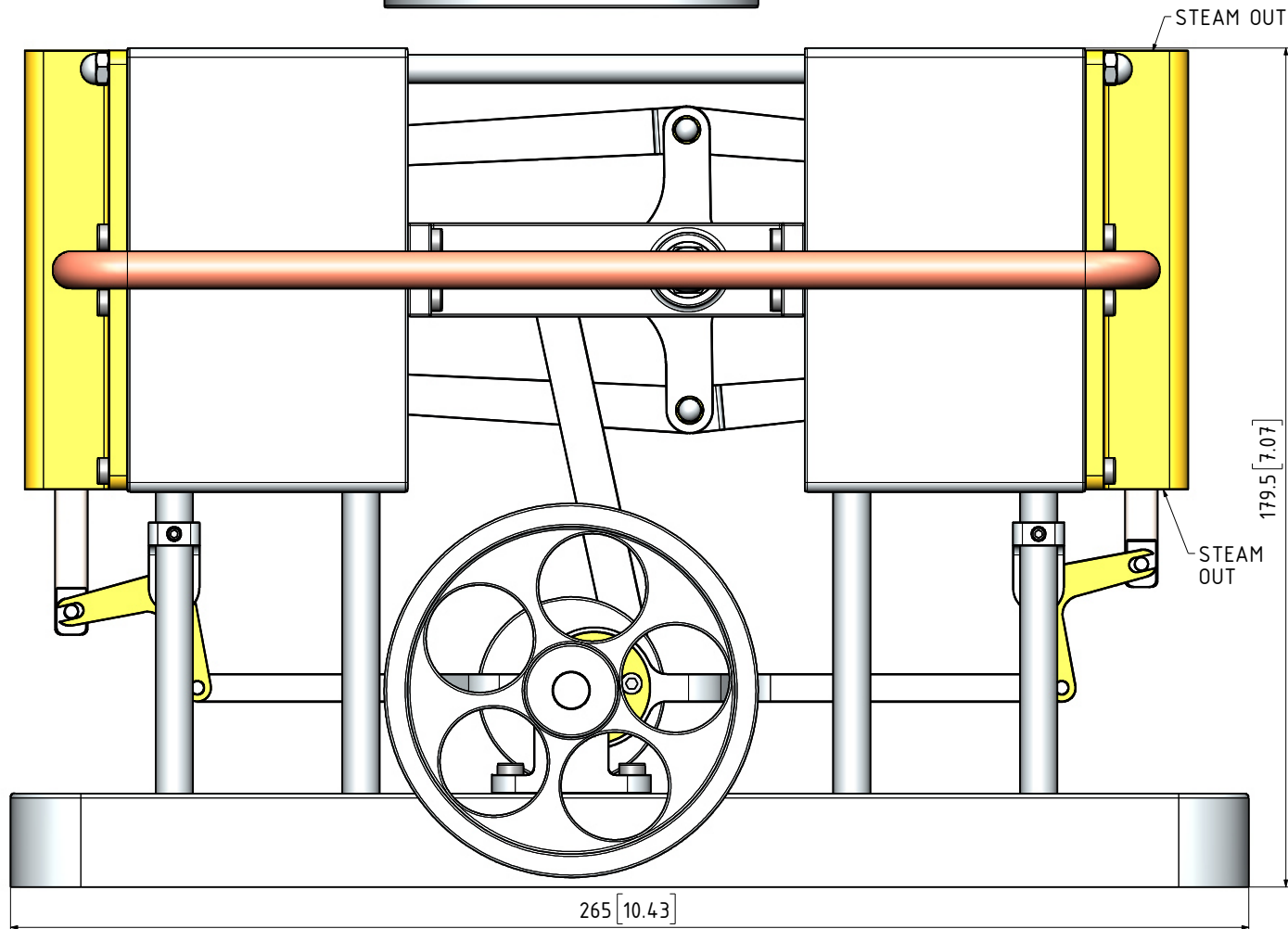
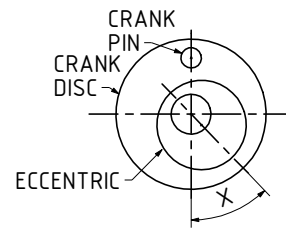

**OTHER ABBREVIATIONS**

- AS = AS SHOWN
- DP = DEEP
- DAA= DRILL AFTER ASSEMBLY
- D&TAA= DRILL AND TAP AFTER ASSEMBLY
- CF = CLOSE FIT (SIZE FOR SIZE)
- PF = PRESS FIT
- PFAA= PRESS FIT AFTER ASSEMBLY
- PCD = PITCH CIRCLE DIAMETER
- RM = REAM
- HEX = HEXAGON, 6SIDED
- CP = COMPRESSED
- KNL = KNURLED
- CSK = COUNTERSINK
- PL = PLACES
- DWL= DOWEL
- SPF= SPOTFACE
- (T)HESOP=(TAPPED)HOLES EQUALLY SPACED ON PCD
- (T)HESOC=(TAPPED)HOLES EQUALLY SPACED ON CIRCUMFERENCE
- OD = OUTSIDE DIAMETER
- ID = INSIDE DIAMETER
- [SA-xxx] = SUB ASSEMBLY-xxx

QTY.	PART NUMBER
1	09D-19-00-1-01-BASE PLATE
8	09D-19-00-1-02-PLATFORM PILLAR
2	09D-19-00-1-03-CYLINDER END COVER
1	09D-19-00-1-04-CYLINDER
2	09D-19-00-1-05-CRANKSHAFT BEARING
2	09D-19-00-1-06-VALVE ROCKER PLATE BEARING
2	09D-19-00-1-07-STEAM SUPPLY PIPE
1	09D-19-00-2-01-ROCKING CRANK
4	09D-19-00-2-02-PISTON
2	09D-19-00-2-03-PISTON CON-ROD-1
2	09D-19-00-2-04-PISTON CON-ROD-2
1	09D-19-00-2-05-CRANK DISC
1	09D-19-00-2-06-MAIN CON-ROD
1	09D-19-00-2-07-ECCENTRIC
1	09D-19-00-2-08-ECCENTRIC STRAP-1
1	09D-19-00-2-09-ECCENTRIC STRAP-2
2	09D-19-00-2-10-VALVE ROCKER
2	09D-19-00-2-11-VALVE
2	09D-19-00-M2.5x6 A-K GRUB SCREW
4	09D-19-00-M3 DOME NUT
4	09D-19-00-M3 WASHER
4	09D-19-00-M3x5 A-K GRUB SCREW
1	09D-19-00-M3x8 A-K C-SINK SCREW
4	09D-19-00-M4 DOME NUT
1	09D-19-00-M4 NUT
1	09D-19-00-M4 WASHER
16	09D-19-00-M4x10 A-K CYL HEAD SCREW
8	09D-19-00-M4x14 A-K CYL HEAD SCREW
8	09D-19-00-M5 NUT
2	09D-19-00-M6 DOME NUT
2	09D-19-00-M6 WASHER

**NOTES:**

0. ALL DRAWINGS ARE IN METRIC MEASUREMENTS
1. ALL ENGINEERING PRACTICES SHALL BE APPLIED WITH REGARDS TO HOLE AND SHAFT TOLERANCES.
2. WHERE SCREWS OR BOLTS ARE USED THE CLEARANCE HOLES SHALL BE APPROXIMATELY 5% TO 8% LARGER THAN THE MATCHING TAPPED HOLE.
3. PREFERABLY ALL TAPPED HOLES AND MATCHING SCREWS AND/OR BOLTS TO BE METRIC FINE (MF)
4. MATERIALS SPECIFIED ON THE DRAWINGS ARE INDICATIVE ONLY. THE BUILDER CAN MAKE HIS/HER OWN MATERIAL CHOICE.
5. ALL CONNECTIONS/JOINTS WHICH HAVE STEAM PRESSURE APPLIED TO IT SHALL BE SILVER/HARD SOLDERED.
6. COMPRESSION SPRINGS ARE DRAWN IN COMPRESSED STATE (CP), UNCOMPRESSED STATE IS APPROX 40% TO 60% LONGER THEN COMPRESSED STATE.
7. WHERE PREFERRED SCREW OR RIVETED CONNECTIONS CAN BE OMITTED AND PARTS CAN BE BONDED TOGETHER BY USING EITHER HIGH STRENGTH GLUE, EPOXY RESIN, OR SOLDER.
8. PARTS WHICH ARE DIRECTLY EXPOSED TO STEAM AND/OR WATER SHOULD BE CONSTRUCTED USING NON-FERROUS OR NON CORROSIVE MATERIAL SUCH AS BRASS, BRONZE, GUNMETAL, STAINLESS STEEL, COPPER OR MONEL.
9. THE ORDER IN WHICH THE PARTS/COMPONENTS ARE MANUFACTURED AND THE MODEL IS ASSEMBLED IS ENTIRELY LEFT TO THE BUILDER/MODEL MAKER.
10. A COLOUR SCHEME FOR THIS PROJECT IS ENTIRELY LEFT UP TO THE MODEL MAKER.
11. THE MANNER IN WHICH THE PARTS/COMPONENTS ARE MANUFACTURED IS ENTIRELY LEFT UP TO THE BUILDER.
12. USE LOCTITE, ON SCREW OR PRESS FIT CONNECTIONS OR SURFACES, WERE DEEMED NECESSARY TO PREVENT PARTS FROM LOOSENING.
13. WASHERS AND/OR SPRINGWASHERS SHALL BE USED WHERE DEEMED NECESSARY.
- XX. ERRORS AND/OR OMISSIONS MAY OCCUR IN THE DRAWINGS, DO NOT HESITATE TO CONTACT ME SO THAT THE ERRORS/OMISSIONS CAN BE RECTIFIED.

**MATERIAL ABBREVIATIONS:**

- ALU = ALUMINIUM
- HALU= HARD ALUMINIUM
- BRS = BRASS
- BRZ = BRONZE OR GUNMETAL (BRZ/GM)
- CI = CAST IRON
- CU = COPPER
- GRA = GRAPHITE
- MS = MILD STEEL/BRIGHT MILD STEEL
- SS = SILVER STEEL OR STAINLESS STEEL
- SPS = SPRING STEEL
- PEEK= POLYETHER ETHER KETONE
- SYN = SYNTHETIC MATERIAL SUCH AS VETON, NYLON, TEFLON OR RUBBER
- nnn/nnn MEANS THAT EITHER MATERIAL CAN BE USED

NOTES: FOUND ORIGINAL UNDIMENSIONED ISOMETRIC SKETCH ON THE INTERNET. REFER TO LAST SHEET FOR DETAILS

TITLE  
**AN EXPERIMENTAL 4 CYLINDER STEAM ENGINE WITH ROCKING CROSSHEAD**

DRAWING CONTENTS  
**GENERAL ARRANGEMENT, NOTES, BILL OF MATERIALS, ISOMETRIC VIEW**

PROJECT No 09D-19-00  
JDW DRAUGHTING SERVICES  
J.A.M. DE WAAL, 12 BRIGHTWELL STREET PAPAOKURA  
2110, NEW ZEALAND. PHONE: 0064 09 2988815. MOB: 0211791000 E-MAIL: dewaal@xtra.co.nz.

PROJECTION  
**JDWDS** MODEL SCALE: 1:1  
DATE MARCH 2020 DWG SCALE: 1:1 @A3 OR AS SHOWN  
SHEET: 01 OF 03 Copyright © J.A.M. DE WAAL PAPAOKURA NZ  
**A3** No: 09D-19-00-SHT01

**DRAWINGS ARE FOR PERSONAL USE ONLY NOT FOR COMMERCIAL PURPOSES**