

NOTES:
 0. ALL DRAWINGS ARE IN METRIC MEASUREMENTS
 1. ALL ENGINEERING PRACTICES SHALL BE APPLIED WITH REGARDS TO HOLE AND SHAFT TOLERANCES.
 2. WHERE SCREWS OR BOLTS ARE USED THE CLEARANCE HOLES SHALL BE APPROXIMATELY 5% TO 8% LARGER THAN THE MATCHING TAPPED HOLE.
 3. PREFERABLY ALL TAPPED HOLES AND MATCHING SCREWS AND/OR BOLTS TO BE METRIC FINE (MF)
 4. MATERIALS SPECIFIED ON THE DRAWINGS ARE INDICATIVE ONLY. THE BUILDER CAN MAKE HIS/HER OWN MATERIAL CHOICE.
 5. ALL CONNECTIONS/JOINTS WHICH HAVE STEAM PRESSURE APPLIED TO IT SHALL BE SILVER/HARD SOLDERED.
 6. COMPRESSION SPRINGS ARE DRAWN IN COMPRESSED STATE (CP), UNCOMPRESSED STATE IS APPROX 40% TO 60% LONGER THEN COMPRESSED STATE.
 7. WHERE PREFERRED SCREW OR RIVETED CONNECTIONS CAN BE OMITTED AND PARTS CAN BE BONDED TOGETHER BY USING EITHER HIGH STRENGTH GLUE, EPOXY RESIN, OR SOLDER.
 8. PARTS WHICH ARE DIRECTLY EXPOSED TO STEAM AND/OR WATER SHOULD BE CONSTRUCTED USING NON-FERROUS OR NON CORROSIVE MATERIAL SUCH AS BRASS, BRONZE, GUNMETAL, STAINLESS STEEL, COPPER OR MONEL.
 9. THE ORDER IN WHICH THE PARTS/COMPONENTS ARE MANUFACTURED AND THE MODEL IS ASSEMBLED IS ENTIRELY LEFT TO THE BUILDER/MODEL MAKER.
 10. A COLOUR SCHEME FOR THIS PROJECT IS ENTIRELY LEFT UP TO THE MODEL MAKER.
 11. THE MANNER IN WHICH THE PARTS/COMPONENTS ARE MANUFACTURED IS ENTIRELY LEFT UP TO THE BUILDER.
 12. USE LOCTITE, ON SCREW OR PRESS FIT CONNECTIONS OR SURFACES, WERE DEEMED NECESSARY TO PREVENT PARTS FROM LOOSENING.
 13. WASHER SHALL BE USED WHERE DEEMED NECESSARY.
 14. IN QUIRE AT THE APPROPRIATE AUTHORITIES WHETHER OR NOT THIS BOILER REQUIRES A PRESSURE TEST CERTIFICATE
 XX. ERRORS AND/OR OMISSIONS MAY OCCUR IN THE DRAWINGS, DO NOT HESITATE TO CONTACT ME SO THAT THE ERRORS/OMISSIONS CAN BE RECTIFIED.

QTY.	PART NUMBER
1	09C-30-00-1-01-BASE PLATE
2	09C-30-00-1-02-SUPPORT COLUMN
2	09C-30-00-1-02-SUPPORT COLUMN
2	09C-30-00-1-03-CRANK SHAFT BEARING
1	09C-30-00-1-04-CYLINDER BASE PLATE
1	09C-30-00-1-05-CYLINDER
1	09C-30-00-1-06-CYLINDER TOP PLATE
1	09C-30-00-1-07-VALVE CHEST
1	09C-30-00-1-08-REVERSING LEVER PLATE
1	09C-30-00-2-01-CRANKSHAFT
1	09C-30-00-2-02-ECCENTRIC SHEAVE-A
1	09C-30-00-2-03-ECCENTRIC SHEAVE-B
1	09C-30-00-2-04-PISTON + ROD
1	09C-30-00-2-05-CON-ROD
1	09C-30-00-2-06-VALVE
2	09C-30-00-2-07-ECCENTRIC STRAP
1	09C-30-00-2-08-EXPANSION LINK
1	09C-30-00-2-09-REVERSING LEVER
1	09C-30-00-2-10-REVERSING LEVER SPRING
6	09C-30-00-M2.5x4 A-K GRUB SCREW
1	09C-30-00-M2.5x7.5 A-K GRUB SCREW
3	09C-30-00-M3 NUT
2	09C-30-00-M3x6 A-K CYL HEAD SCREW
14	09C-30-00-M3x10 A-K CYL HEAD SCREW
6	09C-30-00-M3x12 A-K CYL HEAD SCREW
4	09C-30-00-M3x18 A-K CYL HEAD SCREW
4	09C-30-00-M4x14 A-K C-SINK SCREW

OTHER ABBREVIATIONS
 DP = DEEP
 DAA= DRILL AFTER ASSEMBLY
 D&TAA= DRILL AND TAP AFTER ASSEMBLY
 CF = CLOSE FIT (SIZE FOR SIZE)
 PF = PRESS FIT
 PFAA= PRESS FIT AFTER ASSEMBLY
 PCD = PITCH CIRCLE DIAMETER
 RM = REAM
 HEX = HEXAGON, 6SIDED
 CP = COMPRESSED
 KNL = KNURLED
 CSK = COUNTERSINK
 PL = PLACES
 DWL= DOWEL
 (T)HESOP=(TAPPED)HOLES EQUALLY SPACED ON PCD
 (T)HESOC=(TAPPED)HOLES EQUALLY SPACED ON CIRCUMFERENCE
 [SA-xxx]= SUB ASSEMBLY-xxx

MATERIAL ABBREVIATIONS:
 ALU = ALUMINIUM
 HALU= HARD ALUMINIUM
 BRS = BRASS
 BRZ = BRONZE OR GUNMETAL (BRZ/GM)
 CI = CAST IRON
 CU = COPPER
 GRA = GRAPHITE
 MS = MILD STEEL/BRIGHT MILD STEEL
 S/S = SILVER STEEL OR STAINLESS STEEL
 SPS = SPRING STEEL
 PEEK= POLYETHER ETHER KETONE
 SYN = SYNTHETIC MATERIAL SUCH AS VETON, NYLON, TEFLON OR RUBBER
 IN GENERAL SYNTHETIC MATERIALS SHOULD BE ABLE TO WITHSTAND THE HEAT AND PRESSURE(S) APPLIED TO THEM.
 nnn/nnn MEANS THAT EITHER MATERIAL CAN BE USED

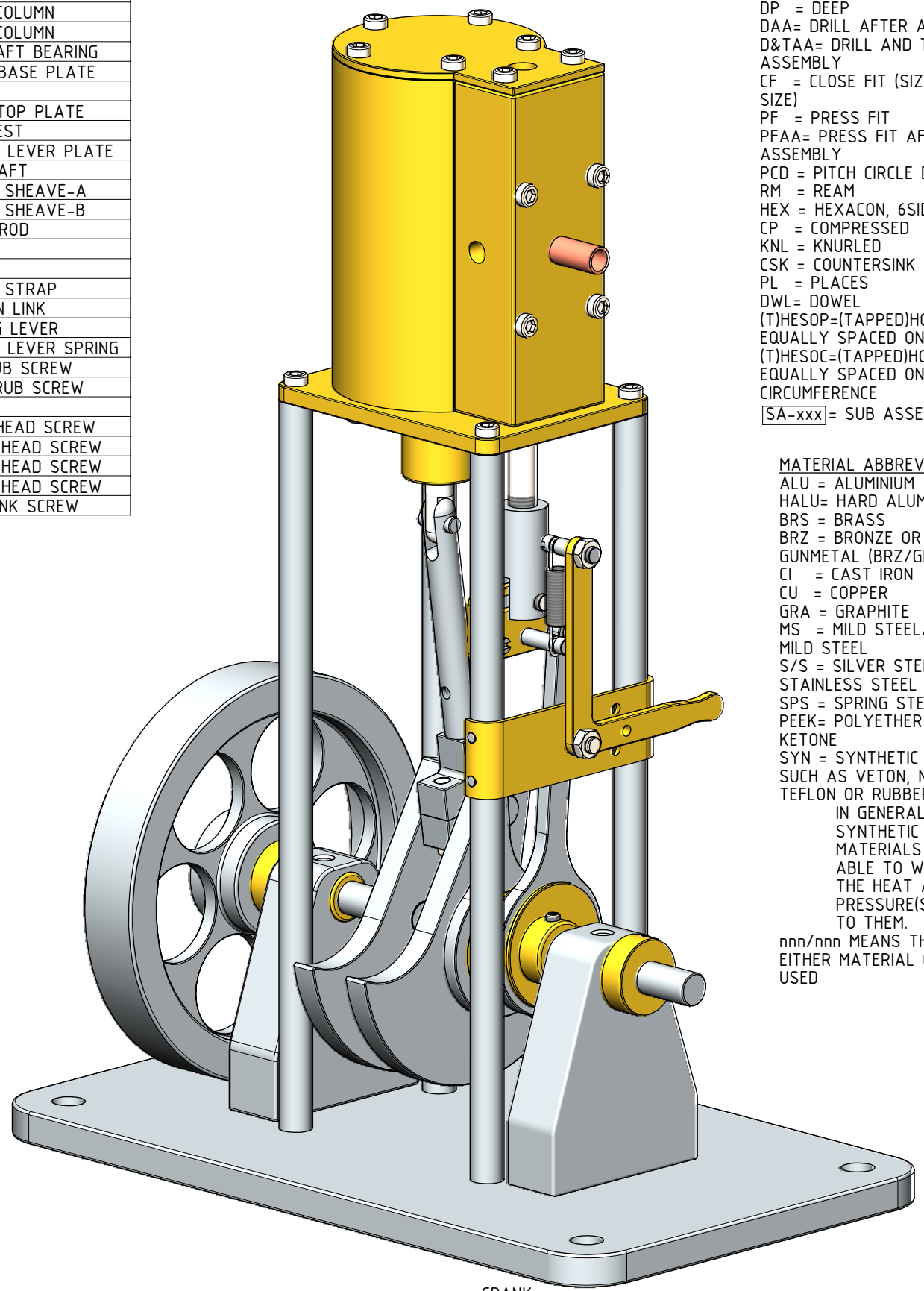
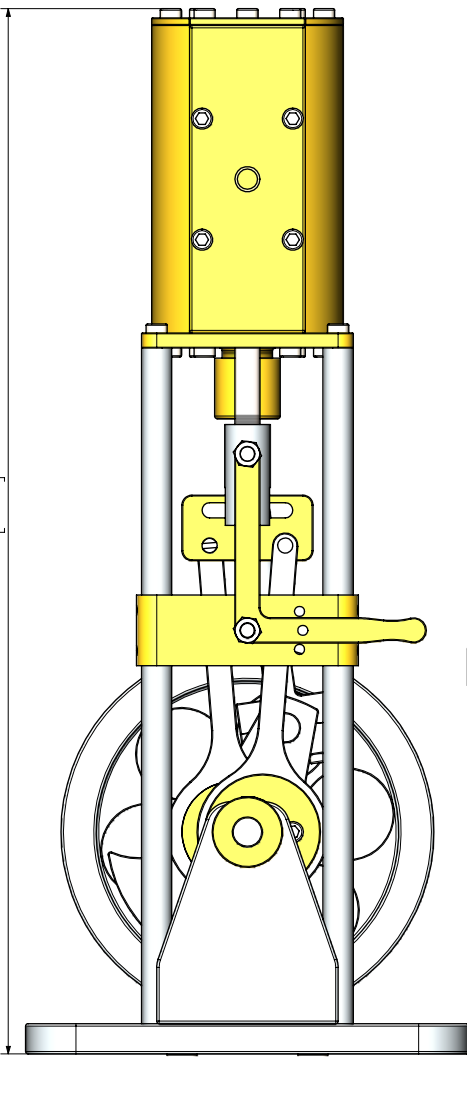
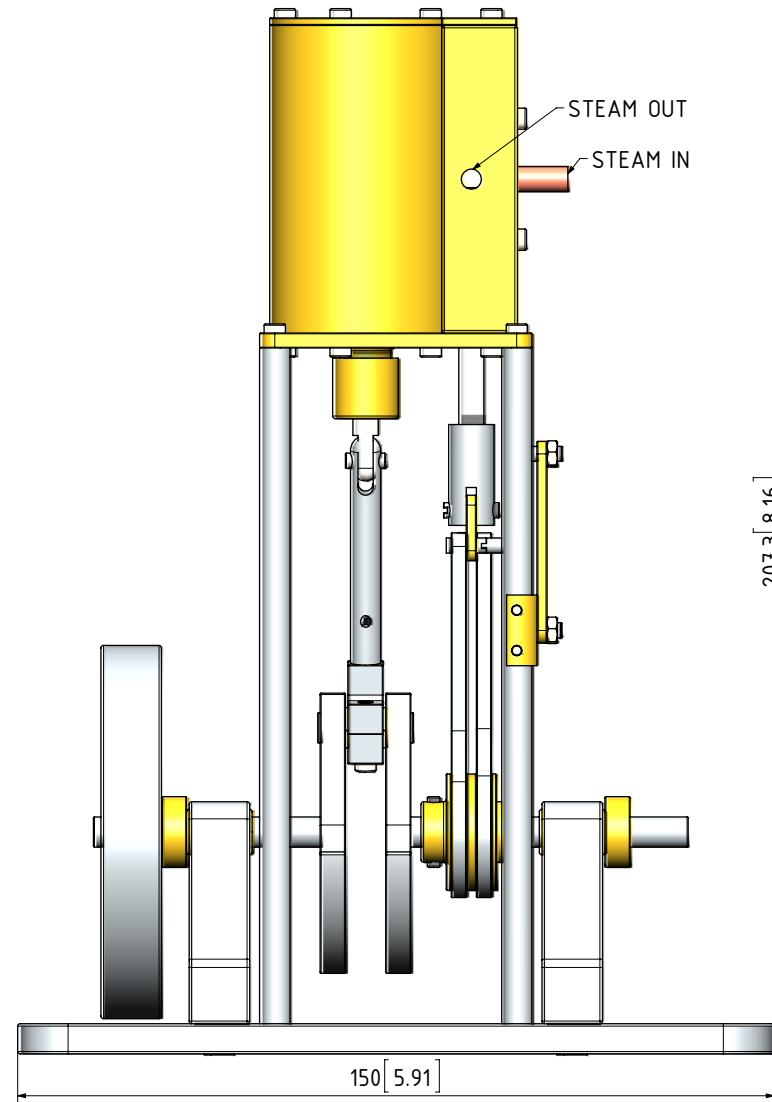
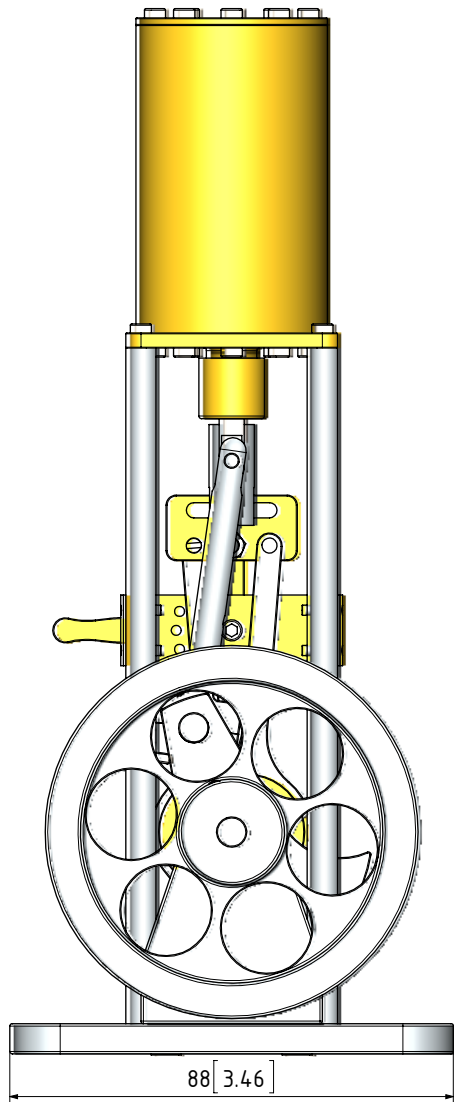

THE OFF SET ANGLE OF THE ECCENTRIC IN RELATION TO THE CRANK AXIS TO BE EXPERIMENTALLY DETERMINED FOR THE SMOOTH RUNNING OF THE ENGINE AND SATISFACTION OF THE BUILDER

