

**NOTES:**

0. ALL DRAWINGS ARE IN METRIC MEASUREMENTS
1. ALL ENGINEERING PRACTICES SHALL BE APPLIED WITH REGARDS TO HOLE AND SHAFT TOLERANCES.
2. WHERE SCREWS OR BOLTS ARE USED THE CLEARANCE HOLES SHALL BE APPROXIMATELY 5% TO 8% LARGER THAN THE MATCHING TAPPED HOLE.
3. PREFERABLY ALL TAPPED HOLES AND MATCHING SCREWS AND/OR BOLTS TO BE METRIC FINE (MF)
4. MATERIALS SPECIFIED ON THE DRAWINGS ARE INDICATIVE ONLY. THE BUILDER CAN MAKE HIS/HER OWN MATERIAL CHOICE.
5. ALL CONNECTIONS/JOINTS WHICH HAVE STEAM PRESSURE APPLIED TO IT SHALL BE SILVER/HARD SOLDERED.
6. COMPRESSION SPRINGS ARE DRAWN IN COMPRESSED STATE (CP), UNCOMPRESSED STATE IS APPROX 40% TO 60% LONGER THEN COMPRESSED STATE.
7. WHERE PREFERRED SCREW OR RIVETED CONNECTIONS CAN BE OMITTED AND PARTS CAN BE BONDED TOGETHER BY USING EITHER HIGH STRENGTH GLUE, EPOXY RESIN, OR SOLDER.
8. PARTS WHICH ARE DIRECTLY EXPOSED TO STEAM AND/OR WATER SHOULD BE CONSTRUCTED USING NON-FERROUS OR NON CORROSIVE MATERIAL SUCH AS BRASS, BRONZE, GUNMETAL, STAINLESS STEEL, COPPER OR MONEL.
9. THE ORDER IN WHICH THE PARTS/COMPONENTS ARE MANUFACTURED AND THE MODEL IS ASSEMBLED IS ENTIRELY LEFT TO THE BUILDER/MODEL MAKER.
10. A COLOUR SCHEME FOR THIS PROJECT IS ENTIRELY LEFT UP TO THE MODEL MAKER.
11. THE MANNER IN WHICH THE PARTS/COMPONENTS ARE MANUFACTURED IS ENTIRELY LEFT UP TO THE BUILDER.
12. USE LOCTITE, ON SCREW OR PRESS FIT CONNECTIONS OR SURFACES, WERE DEEMED NECESSARY TO PREVENT PARTS FROM LOOSENING.
13. WASHERS AND/OR SPRINGWASHERS SHALL BE USED WHERE DEEMED NECESSARY.
14. N/A
- XX. ERRORS AND/OR OMISSIONS MAY OCCUR IN THE DRAWINGS, DO NOT HESITATE TO CONTACT ME SO THAT THE ERRORS/OMISSIONS CAN BE RECTIFIED.

**MATERIAL ABBREVIATIONS:**

- ALU = ALUMINIUM
  - HALU= HARD ALUMINIUM
  - BRS = BRASS
  - BRZ = BRONZE OR GUNMETAL (BRZ/GM)
  - CI = CAST IRON
  - CU = COPPER
  - GRA = GRAPHITE
  - MS = MILD STEEL/BRIGHT MILD STEEL
  - SS = SILVER STEEL OR STAINLESS STEEL
  - SPS = SPRING STEEL
  - PEEK= POLYETHER ETHER KETONE
  - SYN = SYNTHETIC MATERIAL SUCH AS VETON, NYLON, TEFLON OR RUBBER
- IN GENERAL SYNTHETIC MATERIALS SHOULD BE ABLE TO WITHSTAND THE HEAT AND PRESSURE(S) APPLIED TO THEM.
- nnn/nnn MEANS THAT EITHER MATERIAL CAN BE USED

**OTHER ABBREVIATIONS**

- DP = DEEP
- DAA= DRILL AFTER ASSEMBLY
- D&TAA= DRILL AND TAP AFTER ASSEMBLY
- CF = CLOSE FIT (SIZE FOR SIZE)
- PF = PRESS FIT
- PFAA= PRESS FIT AFTER ASSEMBLY
- PCD = PITCH CIRCLE DIAMETER
- RM = REAM
- HEX = HEXAGON, 6SIDED
- CP = COMPRESSED
- KNL = KNURLED
- CSK = COUNTERSINK
- PL = PLACES
- DWL= DOWEL
- SPF= SPOTFACE
- (T)HESOP=(TAPPED)HOLES EQUALLY SPACED ON PCD
- (T)HESOC=(TAPPED)HOLES EQUALLY SPACED ON CIRCUMFERENCE
- [SA-xxx]= SUB ASSEMBLY-xxx

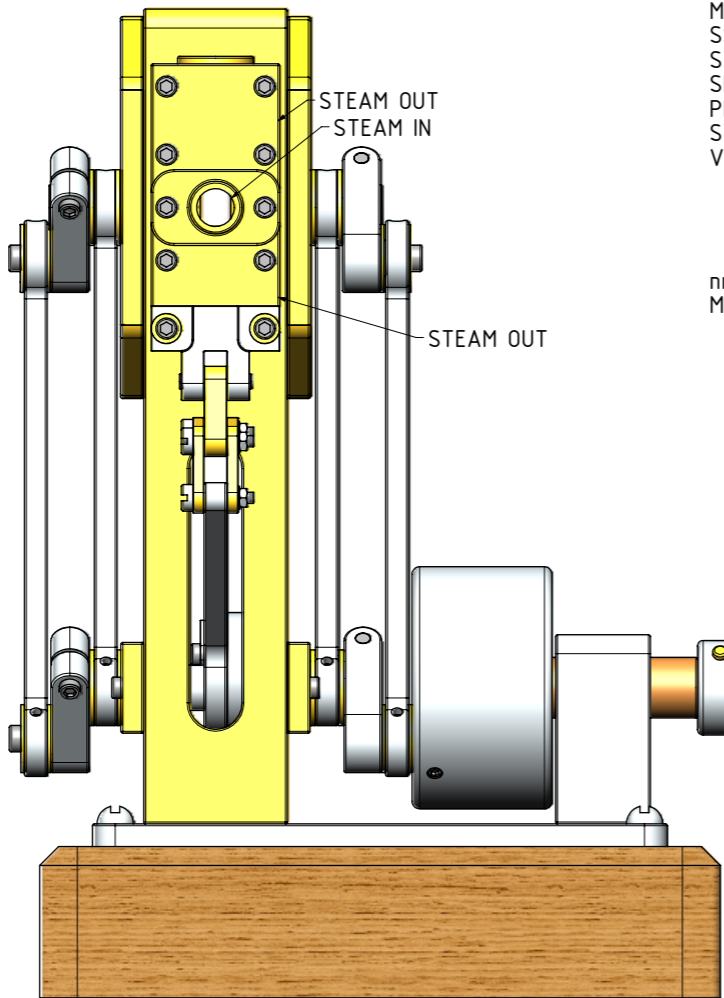
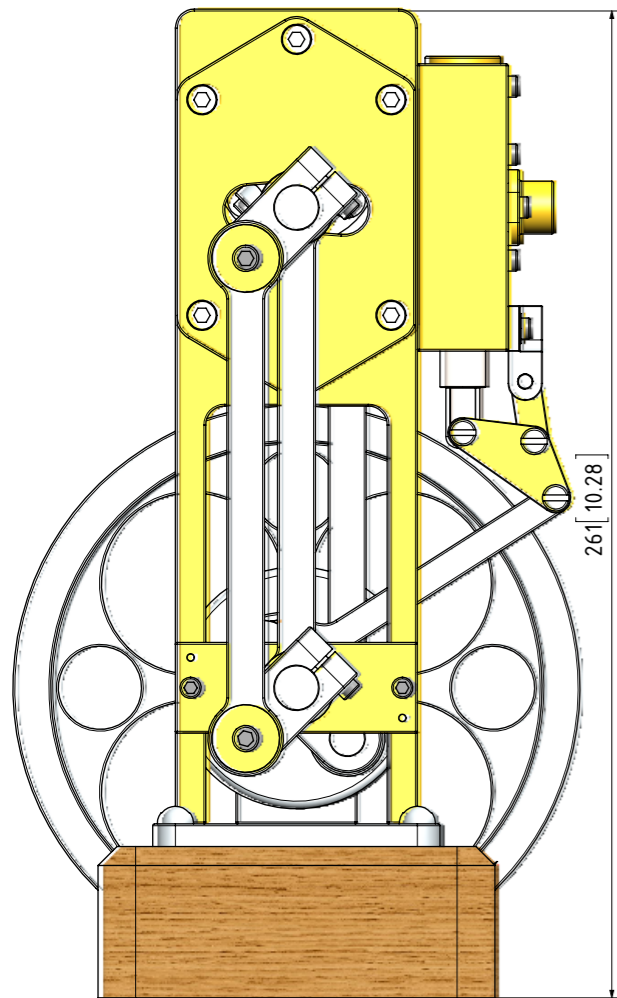

QTY.	PART NUMBER
1	S&S-SE-1-01-BASEPLATE
1	S&S-SE-1-02-FLYWHEEL BEARING
1	S&S-SE-1-03-CYLINDER FRAME
1	S&S-SE-1-04-PORT-VALVE BLOCK
1	S&S-SE-1-05-STEAM INLET PLATE
1	S&S-SE-1-06-VALVE LINK BRACKET
1	S&S-SE-2-01-CRANK SHAFT+ECCENTRIC SHEAVE
1	S&S-SE-2-02-CRANK COUPLING+FLYWHEEL
1	S&S-SE-2-03-CRANK TYPE-1
3	S&S-SE-2-04-CRANK TYPE-2
1	S&S-SE-2-05-PISTON
2	S&S-SE-2-06-CON-ROD TYPE-1
2	S&S-SE-2-07-CON-ROD TYPE-2
1	S&S-SE-2-08-SPOOL VALVE
2	S&S-SE-2-09-LEVER
1	S&S-SE-2-10-LINK
1	S&S-SE-2-11-ECCENTRIC STRAP
3	S&S-SE-2-12-VALVE LINKAGE PIVOT PIN
3	S&S-SE-M3 NUT
3	S&S-SE-M3 WASHER
2	S&S-SE-M4 WASHER
1	S&S-SE-M4x6 A-K CYL HEAD SCREW
1	S&S-SE-M4x8 A-K GRUB SCREW
10	S&S-SE-M4x14 A-K CYL HEAD SCREW
1	S&S-SE-M4x16 A-K GRUB SCREW
4	S&S-SE-M4x18 A-K CYL HEAD SCREW
6	S&S-SE-M4x28 A-K CYL HEAD SCREW
4	S&S-SE-M4x32 A-K CYL HEAD SCREW
3	S&S-SE-M5x12 A-K CYL HEAD SCREW
12	S&S-SE-M5x14 A-K C-SINK SCREW
4	S&S-SE-M6x30-ROUND HEAD WOOD SCREW

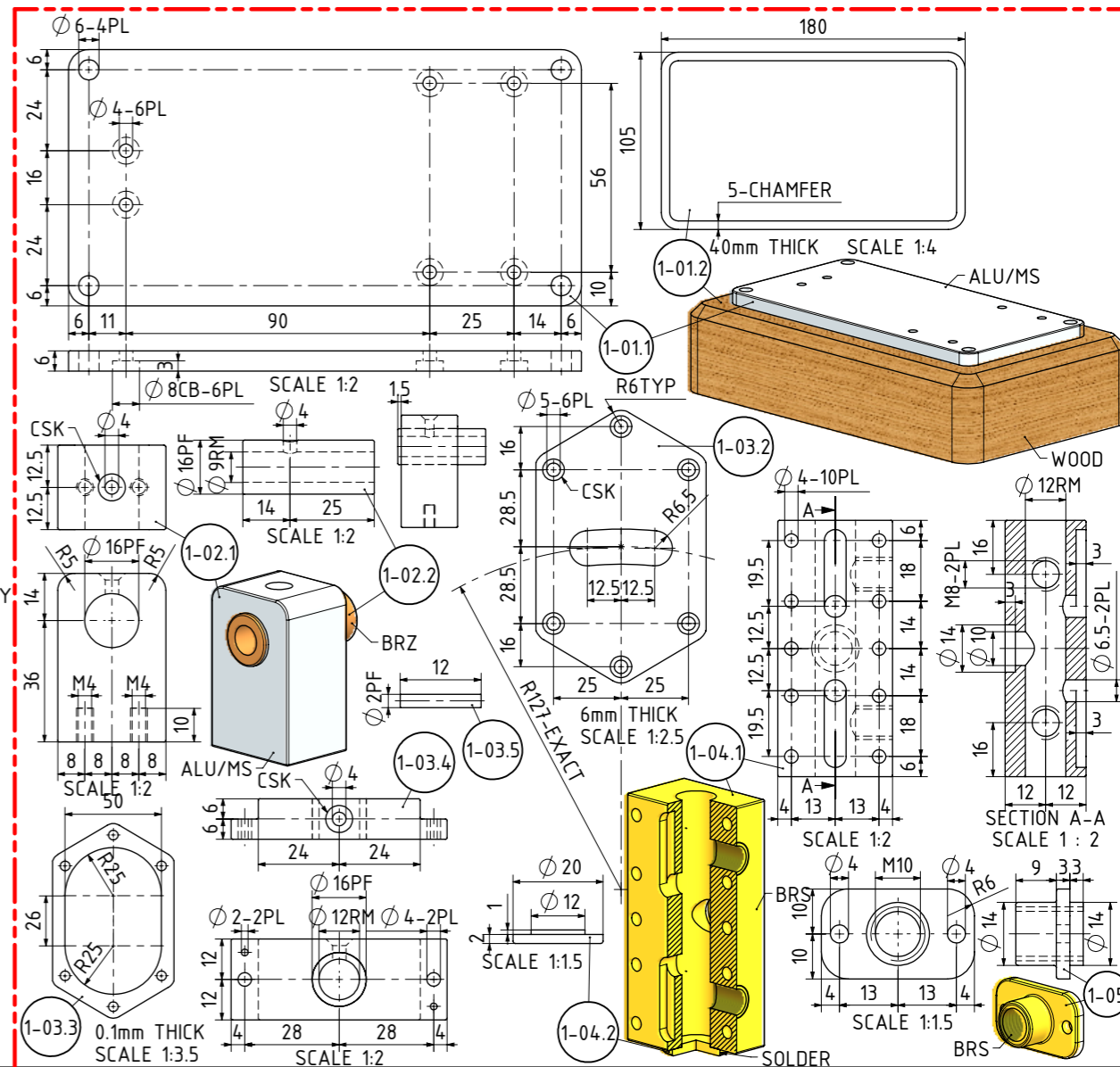

NOTES: THIS DESIGN IS BASED ON A SET OF DRAWINGS WHICH WERE GIVEN TO ME. THE ORIGINAL DRAWINGS AND ARTICLE WERE PUBLISHED IN A UNSPECIFIED MAGAZINE (PAGES 6 TO 10) UNDER THE TITLE "UNUSUAL STEAM ENGINE" BY ROBERT S HEDIN.

TITLE  
**A SIMPLE 1 CYLINDER SIMPSON&SHIPTON TYPE STEAM ENGINE.**

DRAWING CONTENTS  
**GENERAL ARRANGEMENT, BOM, NOTES, PARTS AND ASSEMBLIES**

PROJECT No 09E-27-00  
 JDW DRAUGHTING SERVICES  
 J.A.M. DE WAAL, 12 BRIGHTWELL STREET PAPA KURA 2110.  
 NEW ZEALAND. PHONE: 0064 09 2988815. MOB: 0211791000  
 E-MAIL: dewaal@xtra.co.nz.

PROJECTION  
 DATE AUGUST 2018  
 SHEET: 01 OF 03  
 MODEL SCALE: 1:1  
 DWG SCALE: 1:1 @A3 OR AS SHOWN  
 Copyright © J.A.M. DE WAAL PAPA KURA NZ  
 A3 No: 09E-27-00-SHT01